

# Rhino<sup>®</sup> Cove Cornice

Rhino<sup>®</sup> Cove Cornice is a gypsum finishing product that occupies the area between the wall and ceiling. It is ideal for enhancing the design of your room.

## Performance



Superior Aesthetics  
& Design



Acoustic Control

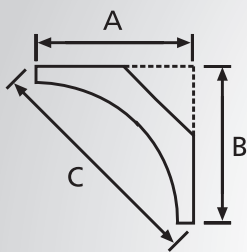
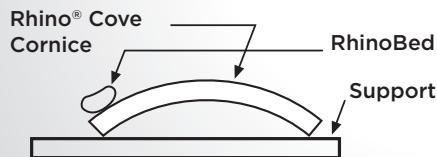
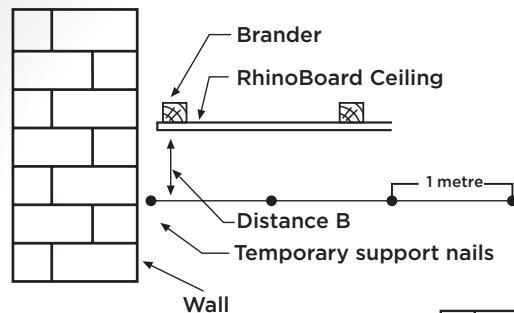
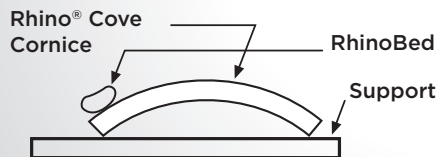
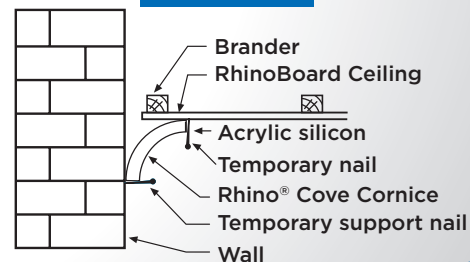

**DIAGRAM 1****DIAGRAM 2****DIAGRAM 3****DIAGRAM 4****DIAGRAM 5****Diagrams and dimensions as follows:**

A x B x C x D ( D=LENGTH) (refer Diagram 1.)

75mm Cove = 58mm x 58mm x 75mm

125mm Cove = 90mm x 90mm x 120mm

1. Measure distance (B) down from the ceiling and mark it on several places on the wall. Shoot a chalk line along these marks on the wall. Insert temporary nails at 1 metre intervals just below the chalk line (Refer Diagram 2).
2. Fix a timber stop along the base of the mitre box distance (A) from the vertical side. Place the cove upside down (i.e. the bottom facing upwards) in the mitre box (Refer Diagram 3). Refer to the catalogue to ensure that you have the pattern the correct way up.
3. Using a fine tooth saw, cut and mitre the required lengths of cove in a mitre box. If using patterned cove, extreme care must be taken to match the pattern where a joint occurs.
4. Lay the cove face down over a length of timber. Butter wall edge with RhinoBed® to more or less the thickness of a finger (Refer Diagram 4).
5. Guide the cove over the temporary nails and press firmly into position against the wall and ceiling. Insert

temporary nails into ceiling to hold cove. Fix the cove ± every metre into the wall using steel nails or drill, plug and screw. On painted surfaces a plaster bonding liquid (Gripdon) should be applied. While still wet and tacky, fix cove. Patch imperfections and clean off excess RhinoBed® (Refer Diagram 5).

**NB:** Always carry cove on edge.

**Note:** Due to the design of modern timber roof trusses, movement and settling will occur. The fixing of cove therefore has to be more flexible. In taking up this movement, it is recommended that all coves be fixed only to the wall and the cove to the ceiling joint be filled with a flexible filler e.g. acrylic silicon.

**Fixing Instructions for Cove to Steel**

1. Fixing of cove with steel branding behind the board could be done in either of these ways:
  - i) Glue the cove to the wall with RhinoBed® with support nails under the cove and in front of the cove in the ceiling, until the bond between cove and wall has formed. Fill the gap at the ceiling with an acrylic silicon.
  - ii) Screw the cove to the ceiling into the steel brander using a screw gun and a screw of suitable length (42mm). Nail the cove to the wall where required. Fill holes with RhinoGlide® and sand when dry.

# HOW TO MITRE CORNICE OR COVE

## Type of corner mitre

There are four different types of mitre cut:

### External angles

- a. Left hand
- b. Right hand

### Internal angles

- c. Left hand
- d. Right hand

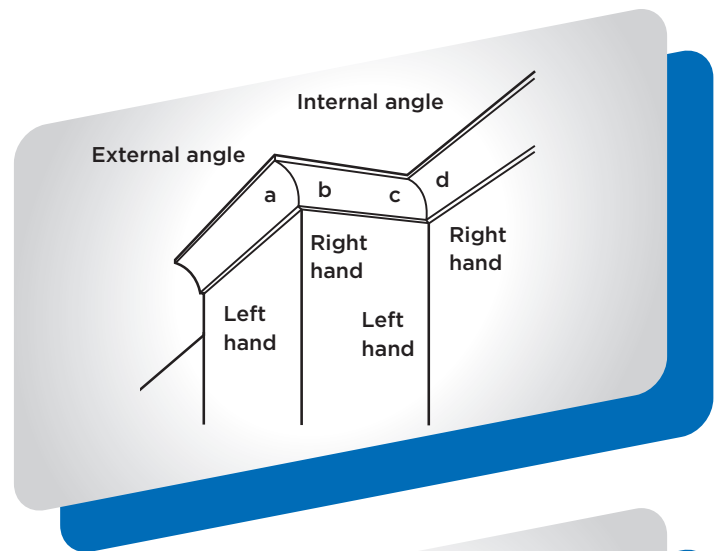

## Mitred joints

To cut a left hand corner mitre, position the mitre block to the left of the length of cove and line up the measured mark with the appropriate mitre block slot (depending on whether the angle is to be internal or external). Similarly, position the mitre block to the right of the length of cove for the right hand corners.

**Before starting, note which way up the cornice should be fitted.**

Remember that all marks, measurements and cuts must be made from the back of the cove's wall edge. When measuring for mitres or butt joints, try to ensure a good pattern match at the meeting edges. This is especially important with external mitres, which are generally more visible. So, whenever a mitre is required, measure the distance between the end of the last fixed length and the corner of the room. Mark this measurement on the back wall edge of the next length of cove - making sure the pattern matches at each point.

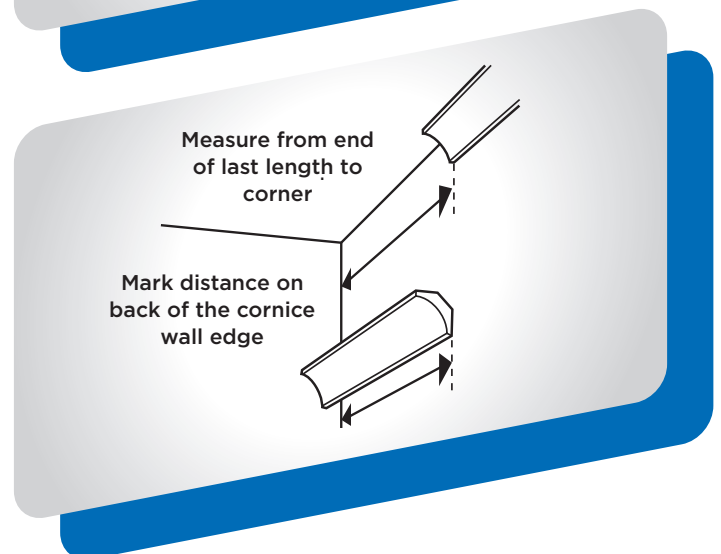
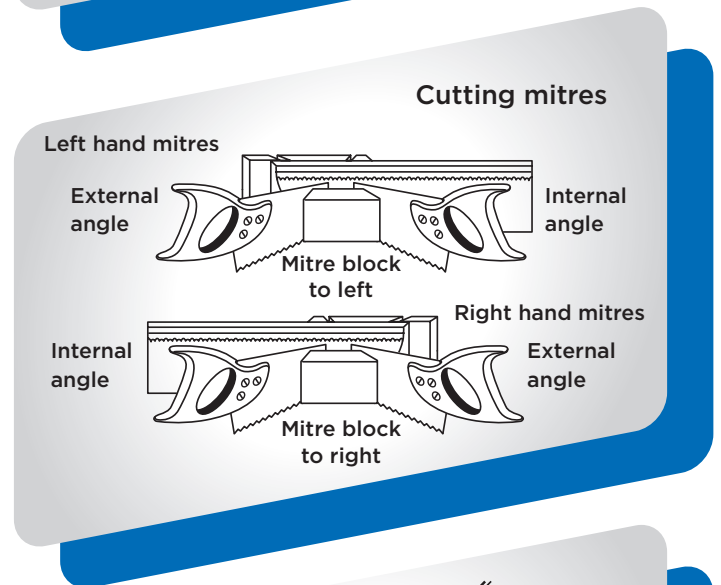

## Cutting cove

When using the mitre block, it is a good idea to keep the cove supported and level using a piece of wood the same thickness as the base of the mitre block. Place the cove upside-down in the mitre block with the wall edge uppermost, flat against the side, and the ceiling edge flat against the base.

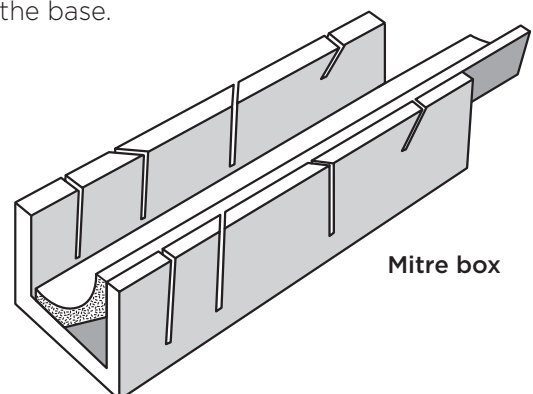
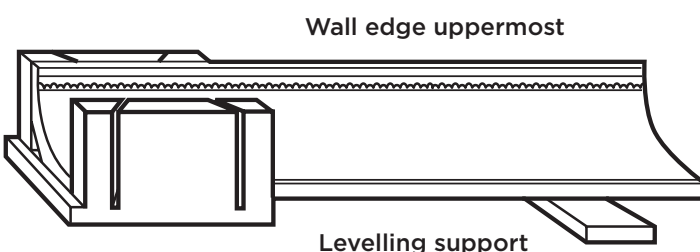

## Rhino® Cove Cornice Pre-mitred Corners

Cove installations are quicker and neater with new easy to fit Rhino® Cove Cornice pre-mitred corners.

Distinct, clear edge that does not require filling or patching.

Snug fit onto the curve of a Rhino® Cove Cornice 75 mm gives a neat finish.

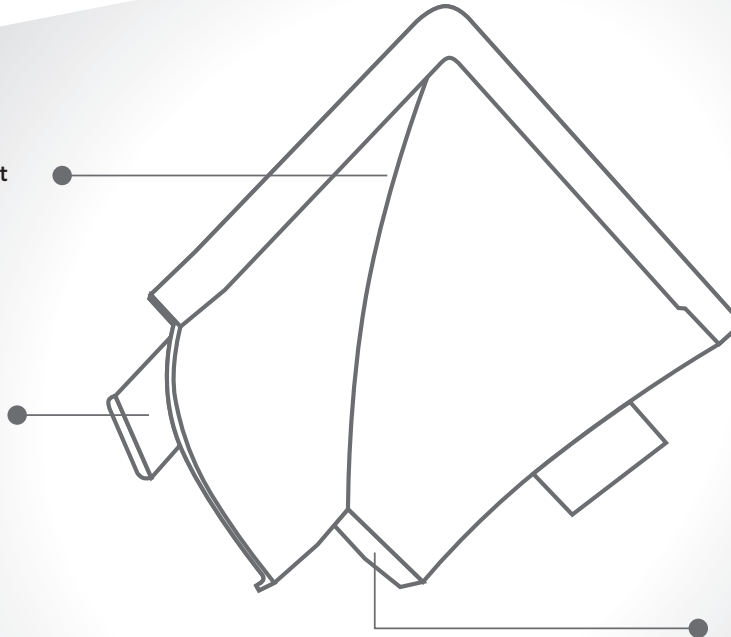

Pre-moulded 45° angle for external and internal corners that eliminate mitre boxes and saves time on installations.



2 Outer corners



4 Inner corners



28 pack Inner corners



**GYPROC** a division of Saint-Gobain Construction Products SA (Pty) Ltd

300 Janadel Avenue • Halfway House  
• Midrand 1686 • South Africa

PO Box 50416 • Randjiesfontein  
• 1683 • South Africa

+27 (0)12 657 2800

[www.gyproc.co.za](http://www.gyproc.co.za)

South Africa, 06/2024. Gyproc reserves the right to modify data without prior notice. If required, please contact the Gyproc Technical Department. Saint-Gobain Construction Products South Africa (Pty) Ltd.

Reg no: 1937/010220/07

